

IMPLEMENTATION OF REAL TIME BRAINWAVE VISUALISATION AND CHARACTERISATION

K. SURESH MANIC, C.V. ARAVIND*, A. SAADHA, K. PIRAPAHARAN¹

School of Engineering, Taylor's University, Taylor's Lakeside Campus,
No. 1 Jalan Taylor's, 47500, Subang Jaya, Selangor DE, Malaysia

¹University of Technology, Papanewguniea

*Corresponding Author: aravindcv@ieee.org

Abstract

Human brain is the most complex organ in the body which controls all conscious and unconscious aspects of the body. Numerous neurons combine together to make up the brain and gives us the power of speech, imagination and logical thinking. The communication between these neurons create magnetic and electric field that can be measured through an Electroencephalograph. These measured brainwaves consist of component bandwidths categorised based on their frequency. Studies have shown that the presence of these waves in the brainwave depend on the emotional and mental status of the person as well as physical and mental actions that are being carried out. This paper looks into the different aspects of acquiring these brainwaves in real time and conditioning the waves in order to remove unwanted artefacts for digitisation and signal analysis. An in depth study is carried out for obtaining the waves through a data acquisition device DAQ 6009 and the categorisation of the brainwave to different components through the software platform LABVIEW. Studies are then conducted to analyse the brainwaves during different conditions to create a database of what a brainwave constitute of at a particular activity. A standalone modular unit is developed that could be used to acquire; store and analysis the brain wave signal in real time and is tested for its performance.

Keywords: Brain signal visualisation, Characterisation, Portable model.

1. Introduction

Human brain encloses four structures each with a different set of functions related to the activity state of the physical motion [1]. Each movement, perception and thought beings distinct neural activation pattern. Electroencephalography (EEG) is a tool used to record this brain activity and

characterises the field potentials ensuing from the combined activity of impulses from the neuron nodes. It is measured using the surface electrode plates onto the skin of the scalp. There are five different band limits for the brain wave, namely delta, theta, alpha, beta and gamma. These five band limits are characterised based on the frequency range which is normally from 1 Hz to 60 Hz, with amplitudes of 10 to 100 micro-volts [2].

Although EEG has been in use for a relatively long time, the recognition of brainwave patterns, the separation of brainwaves and categorising them in the literature are minimal [3]. Moreover the current apparatus available for measuring EEG waves are bulky thus restricting the flexibility of operating conditions and the movement of the user.

This paper presents acquire, analyse and predict using a portable device that can acquire brainwaves, identify and differentiate between the frequencies consisted in the signal with the help of a signal processing software. Such a device enable discerning various human afflictions such as a person's mental health by measuring the stress levels and hence provide proper counselling. Real time gaming is another area that this technology ushers through providing the method of creating mind control games.

Initial research built through the characterisation and separation of brain wave frequency mocked through electronic circuits. Once confirmed on the same design using LABVIEW and signal acquisition board the realisation is presented through different cases and frames of mind condition. The results presented are limited to the conditions that the subject is completely healthy when the measurements are taken.

2. Research Design

The research design embraces two stages, the first one involves the characterisation and separation of brain wave signals using the frequency realisation through frequency generator, mixed together then using the hardware software interface reclassify and restore the signals to original conditions.

2.1. Characterisation and separation of brain wave signal [4]

Figure 1 shows the block diagram of characterisation and separation of the brain wave signals. As shown the signals from the function generator, the signal conditioning and acquisition is characterised through hardware. The addition of signal to create a mixed signal that represents the brain wave signal and the filtration into the different bands are carried out through the software. Band pass filters are implemented in LABVIEW to filter out the components of the mixed wave form. A Graphical User Interface (GUI) as in Fig. 2 is then developed through LABVIEW in order to make it easier for users to visualise the data. This interface shows the activity of the signal generator, the signal that is obtained and the filtered out signals and is displayed. The laboratory setup is as shown in Fig. 3.

The signal is obtained from five different signal generators (S1, S2, S3, S4, S5) each of which represent a band of the brainwave signal. It is then passed through a signal conditioning circuit consisting of a 60 Hz notch filter, used for

eliminating the noise accumulation from the 60 Hz power supply. Since brainwaves are between the frequencies of 3 Hz-60 Hz the signal passes through a 60 Hz low pass filter and a 3 Hz high pass filter. This removes other frequency bands that are acquired through the sensor.

Butterworth filters constructed using LM741 amplifier is used for a smoother response and unity gain in order to eliminate any noise amplification. The conditioned signal then passes through DAQ 6009, a data acquisition device used for simple data logging and portable measurement. The Nyquist Shannon sampling theory states that the sampling frequency must be twice that of the highest frequency of the signal hence for brainwaves giving a sampling rate of 120 Hz [5]. However for a better reconstruction of the signal (F1, F2, F3, F4, F5) since it is of very small amplitude, 15 mV a much higher sampling rate of 5 kilo-samples per second is used. Signals that are sampled from the Data Acquisition (DAQ) are sent to a signal processing software, LABVIEW [3].

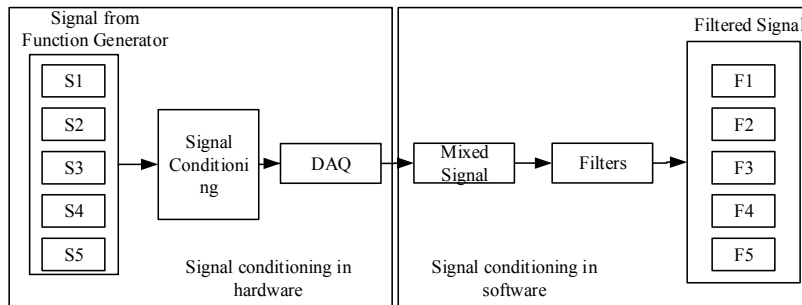

Fig. 1. Block diagram for characterisation of the brainwaves through function generators.

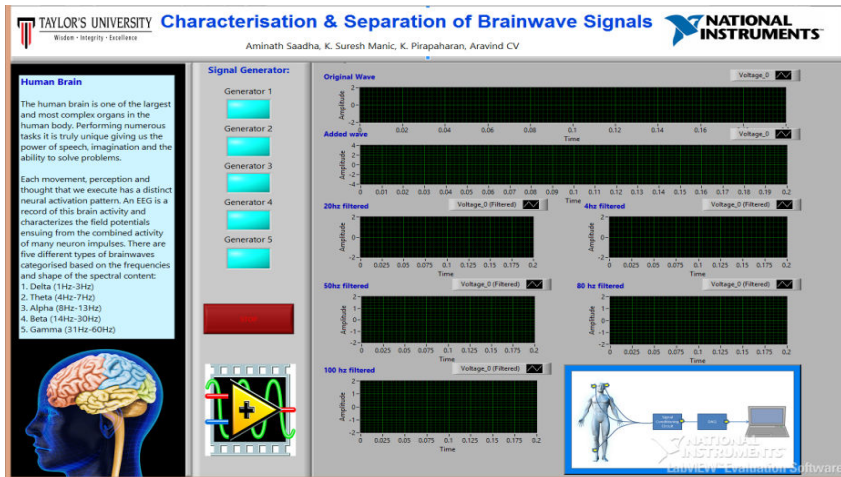

Fig. 2. Graphical user display to acquire the separated signal.

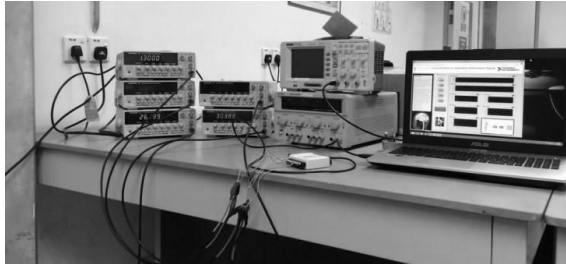

Fig. 3. Laboratory setup for characterisation of the brainwaves through function generators.

2.2. Realisation of the system design [5]

Once the characterisation of the brain wave signals is done and tested with the designed interface electronic circuits the brain wave signal is acquired analysed for different frame of mind of the subject through the industry standard electrodes. One of the active electrode and the neutral electrode are placed on the forehead just below the hairline. For maximum EEG signal acquisition the third electrode is placed at the back of the head just above the bump of the skull. Tests are conducted to evaluate the software and assess whether the five different filters in the setup perform correctly. In test 1, two case studies are conducted since the device is intended to be used for people with different personality, meaning that the brainwaves vary from person to person. In the first case signals are all within the frequency band of the band pass filter.

This test assumes that all the frequencies of brain waves are present in this signal and tests the detection of all the frequencies. In case 2 the signal from a signal generator is changed so that it does not fall in any filter category. This signal assumes that the subject does not produce one frequency of brain wave at that moment and all other frequencies are being detected. A second test is designed to check whether the intensity of the brain wave is detected by the software. For this study the amplitude of the 4 Hz signal generator is increased from the input while the amplitude of other frequencies is maintained constant. The block representation on the system setup is as shown in Fig. 4. Figure 5 shows the graphical programming used in the system design for the LABVIEW real time interface system. The complete system setup during the recording of the data is as shown in Fig. 6(a) and (b) shows the electronic circuit design for the proposed system in data acquisition. Figure 7 shows the filtering stages of the brain wave signals for various frequency range of operations.

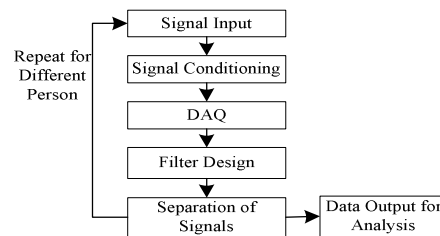

Fig. 4. Methodology used in this brainwave separation analysis.

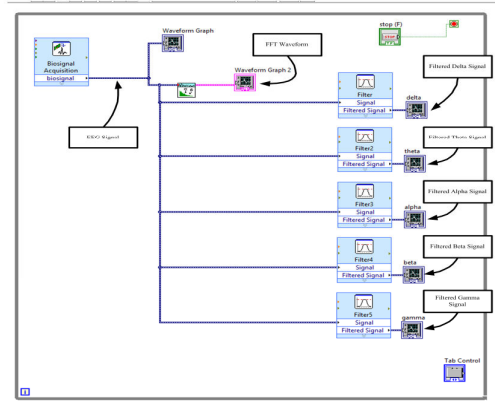

Fig. 5. Graphical programming of the system design.

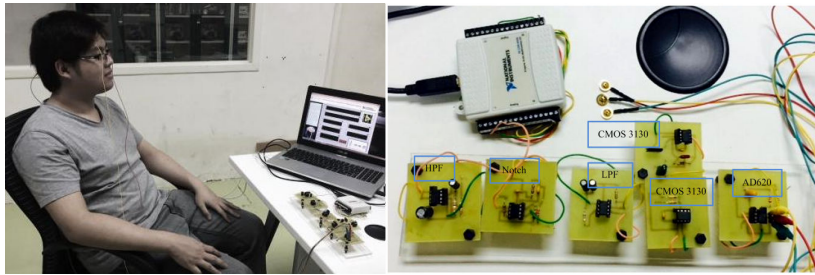

Fig. 6. Complete portable system design setup, (a) system with the subject and (b) hardware electronic filter design.

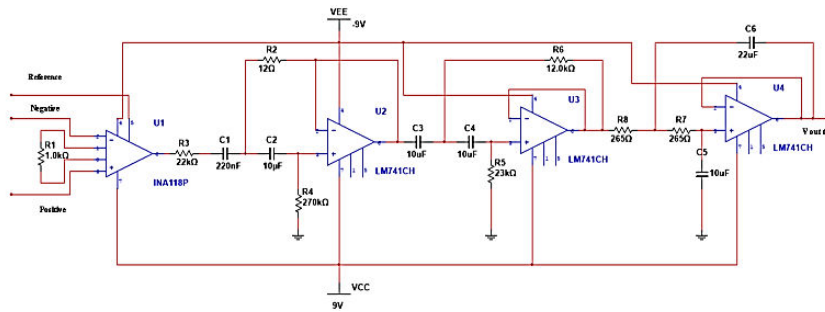

Fig. 7. Electronic filter stages of the research design.

3. Results and Discussions

In the first case data is taken after the subject is given enough time to properly relax, calm their thoughts and empty the mind. In the second case subject is given a mathematical question to solve before taking the readings. Data is taken

5 minutes into the exercise. This is shown with subject as in Fig. 8. In the third instant the subject is observed for the change of pattern from the relaxing mode to that of the intense mind thinking.

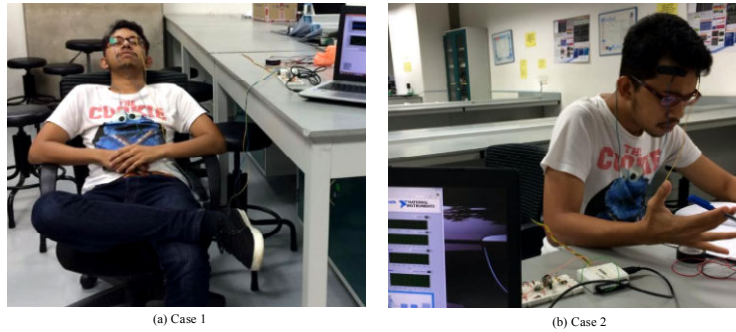

Fig. 8. Subject under relaxed and intense thinking.

3.1. Case 1: relaxed mode

The subject is given 15 minutes to listen to some relaxing music and sit in a relaxed position in an office ergonomic chair with a good back rest. This gives the subject enough time to properly relax, calm their thoughts and empty the mind. After the fifteen minutes readings are taken from the subject while sitting down and with eyes closed. Signals are acquired and analysed for 3 different subjects and the results are tabulated in Table 1.

As seen from Fig. 9(a) from the component signals of the brainwave the alpha wave is most predominant with 15 mV amplitude corresponding to 70% intensity. The power spectrum analysis also corresponds with this high amplitude and shows a larger peak at the frequency of alpha waves between 8-13 Hz. The beta and gamma waveforms have amplitude of 6 – 6.4 mV. Fig. 9(b) displays the results for subject 2 under the same conditions. These results correspond with the results of subject 1.

Table 1. Ratio of amplitude of component bandwidth for Case 1.

Subject	α Wave	β Wave	γ Wave
1	0.7	0.2	0.1
2	0.8	0.19	0.2
3	0.5	0.3	0.1

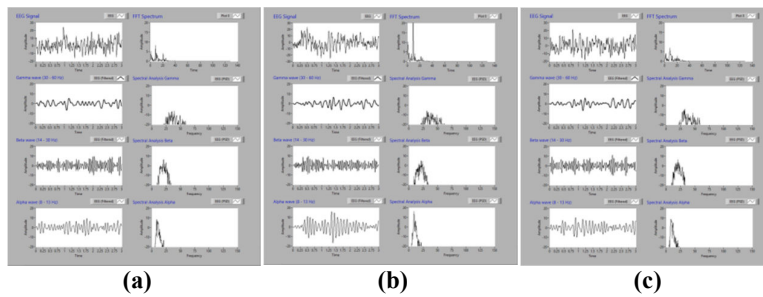

Fig. 9. Relaxed mode characteristics for 3 different subjects.

However the amplitude of the detected alpha while predominant from other bandwidths is a bit higher and is seen by the slightly higher amplitude of 16 mV. The power spectral analysis of the alpha wave verifies this and shows greater peak amplitude from before. This indicates that this subject is more relaxed and therefore emitting alpha waves of higher intensity. The beta and gamma waves are of lower amplitude still corresponding to only 20% of the wave form. As seen from Fig. 10 from the component signals of the brainwave the alpha wave is most predominant with 10 mV amplitude corresponding to 50% intensity. The beta and gamma waveforms have amplitude of 4-4.4 mV. This subject has a lower intensity of alpha waves compared to others hence his relaxation is not as deep at the time of signal acquisition.

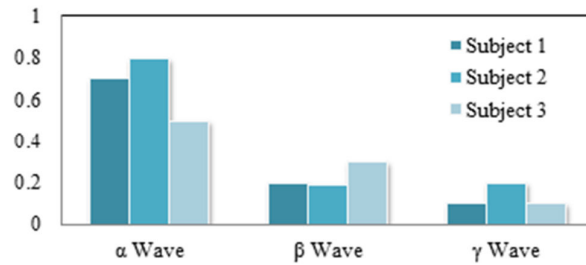

Fig. 10. Comparison of bandwidths of relaxed mode.

3.2. Case 2: Intense mental thinking

The subject is given a mathematical question with fifteen minutes to complete it as shown in Fig. 11. Brainwaves are acquired 5 minutes into the exercise while the subject is still answering the problem. The duration for completing the exercise in order to ensure that the subject does not slack off and is really into thinking on solving the problem. Table 2 summarises the results indicating the distribution of power among the bandwidths.

Table 2. Ratio of amplitude of component bandwidth for Case 2.

Subject	α Wave	β Wave	γ Wave
1	0.2	0.7	0.1
2	0.17	0.78	0.3
3	0.23	0.67	0.21

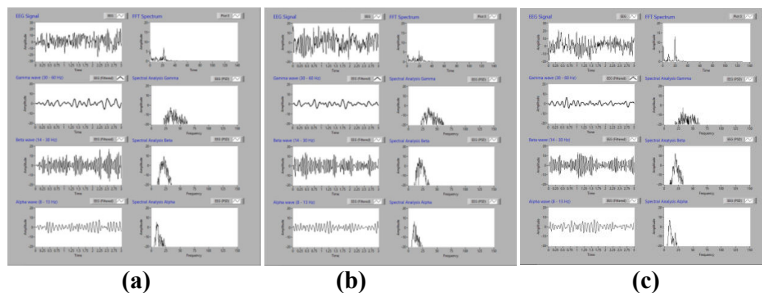

Fig. 11. Intense mental thinking mode characteristics for 3 different subjects.

As seen from Fig. 11(a) from the component signals of the brainwave the beta wave is most predominant with 15 mV amplitude corresponding to 70% intensity. The power spectrum analysis also corresponds with this high amplitude and shows a larger peak at the frequency of beta waves between 14-30 Hz. The alpha and gamma waveforms have amplitude of 5.5-4 mV.

Figure 11(b) displays the results for subject 2 under the same conditions. These results correspond with the results of subject 1. However the amplitude of the detected gamma while predominant from other bandwidths is a bit higher and is seen by the slightly higher amplitude of 15.6 mV. The power spectral analysis of the beta wave verifies this and shows greater peak amplitude from before. This indicates that this subject is performing more logical thinking and therefore emitting beta waves of higher intensity. The alpha and gamma waves are of lower amplitude still corresponding to only 15% of the wave form.

As seen from Fig. 12 from the component signals of the brainwave the beta wave is most predominant with 13.4 mV amplitude corresponding to 67% intensity. The beta and gamma waveforms have amplitude of 3-3.4 mV. This subject has lower intensity of beta waves compared to others.

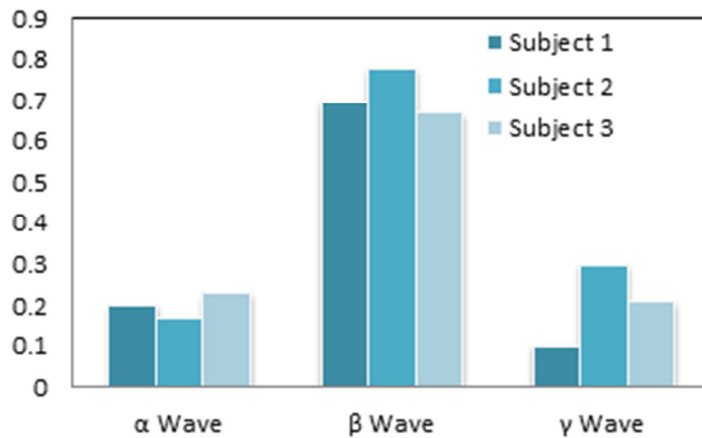

Fig. 12. Comparison of bandwidths of intense mental thinking mode.

3.3. Case 3: Changes in brainwave when going from relaxed to intense mental thinking

The subject is at first allowed to relax and then after 10 minutes of relaxation a mathematical problem is given to subject to solve. Brainwave readings are taken every five minutes to measure the alpha and beta waves to see the changes in component brainwaves with change in mental activity. Table 3 shows the power spectrum readings for the changes at five minute intervals.

Figure 13 shows the changes in beta value over time as the subject transitions from mental relaxation to intense mental thinking. It can be seen that the alpha waves are dominant, having a higher amplitude during the first 10 minutes while the subject is not thinking with the eye closed. After the ten minutes the beta waves take dominance as indicated by Fig. 14 showing that these waves are

abundant and almost of 70-80% when subject undergoes intense mental thinking while trying to solve the mathematical problem.

Table 3: Ratio of amplitude of component bandwidth for case 3.

	Time							
	5		10		15		20	
	α	β	α	β	α	β	α	β
Subject 1	0.60	0.3	0.70	0.43	0.20	0.70	0.18	0.69
Subject 2	0.75	0.25	0.64	0.22	0.17	0.78	0.35	0.75
Subject 3	0.54	0.17	0.67	0.3	0.23	0.67	0.14	0.55

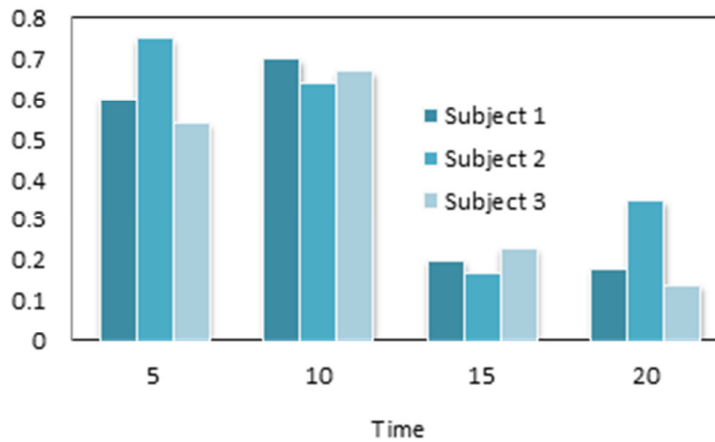

Fig. 13. Change in alpha over time.

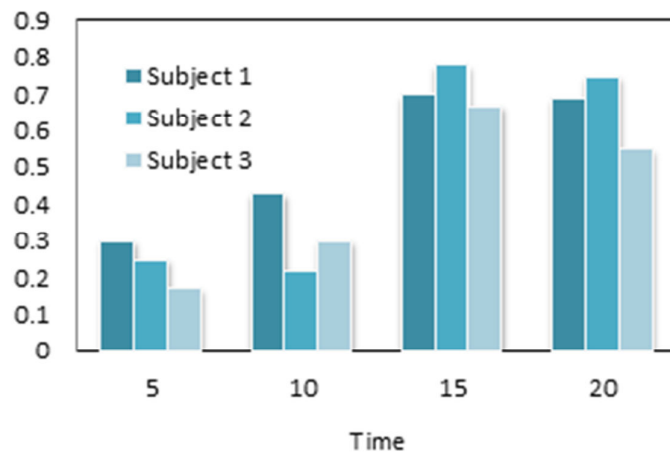

Fig. 14. Change in beta over time.

4. Conclusions

This research proposes a system that will allow for real time acquisition of EEG waves. The system is at designed by realising the brainwaves through the usage of different function generators and then the design is tested by applying known frequencies as input. This design is then implemented in real time through the usage of electrodes for obtaining the brainwaves. A signal conditioning circuit is then designed to remove unwanted noise and hence allow for a better digitisation of the signal. It is found that the proposed system is with an error of 5.27%. The system is then tested at different conditions to test the conditions of the brain and to see the type of wave that is emitted at these conditions. It is found that alpha waves are dominant during relaxation almost at 60% and beta waves are of 70% during intense mental thinking.

References

1. Alan Longstaff (2005). *Neuroscience*. (2nd Ed.), Taylor & Francis Group, New York.
2. Hoole, P.R.P.; Pirapaharan, K.; Basar, S.A.; DLDA, Liyanage; SSHMU , Senanayake; SRH, Hoole; and Ismail, R. (2012). Autism, EEG and brain electromagentic research. *Biomedical Engineering and Sciences*, 1(1), 5-6.
3. Ramesh, G.P.; Aravind, C.V.; Rajparthiban, R.; and Soysa, N. (2014). Body area network through wireless technology. *International Journal of Computer Science and Engineering Communications*, 2(1), 129-134.
4. Saadha, A.; Suresh Manic, K.; Pirapaharan, K.; Aravind, C.V. (2014). Universal interface tool for characterisation and separation of brain wave analysis using LABVIE. *Proceedings of First IEEE EMBS International Student Conference*, Malaysia.
5. Saadha, A.; Suresh Manic, K.; Pirapaharan, K.; Aravind, C.V. (2014). Characterisation and separation of brain wave signals. *Proceedings of 2nd Engineering Undergraduate Research Catalyst (eureca 2014) Conference*, Malaysia.