

## ADVANCEMENT IN CONSTRUCTION MATERIALS AND CHALLENGES IN FINDING STRUCTURAL SOLUTIONS FOR MODERN STRUCTURES

**B. Kiriparan<sup>1\*</sup>, B. Waduge<sup>1</sup>, W. J. B. S. Fernando<sup>1</sup>, Udayanga Alwis<sup>1</sup> and P. Mendis<sup>2</sup>**

<sup>1</sup> *Civil and Structural Engineering Consultants (pvt)ltd, Sri Lanka.*

<sup>2</sup> *University of Melbourne, Australia.*

\* *Correspondence E-mail: kiriparan@csec.com.lk , TP: +94719922602*

**Abstract:** In modern construction arena architecturally driven designs with more sophisticated structural forms offers several challenges to the structural engineers and contractors. In addition to the architectural superiority, safety, structural stability, serviceability, functionality, economic feasibility and constructability are different factors to be critically considered in a conceptual design. In order to achieve a sustainable design all these important factors has to be integrated in the design in an optimum manner. Structural engineer plays an important role in this context from the initial stage up to the construction completion. Selection of efficient structural scheme and suitable construction material, carryout structural analysis, verify the design to satisfy all design criteria, provide wise detailing and ensure the constructability are few among such important functions. This paper presents application of different construction materials such as timber, steel, concrete and composites in modern architecturally driven designs. Importance of utilizing structural materials appropriately, structural idealizations for analysis, design and detailing were emphasized. Selected case studies authors has designed in the recent past, containing such structural significances were used for the demonstration.

**Keywords:** Construction materials; Architecturally driven designs; Structural challenges; Sustainable designs

### 1. Introduction

Modern design of iconic projects are mostly architectural driven with complicated geometries. This commonly requires sophisticated structural forms that preserve the architectural design intent. Careful understanding of behaviour of the structural system and load transferring mechanism are vital to provide a workable and safe structural solution. Factors such as safety, structural stability, serviceability, functionality, economic feasibility and constructability are to be thoroughly studied and inbuilt in the structural design. Apart from conventional reinforced concrete construction, alternative materials like timber, steel and composites are frequently adopted in such instances. These construction materials provide several added advantages over conventional reinforced concrete. Strength, stiffness, light weight, construction flexibility, aesthetic appearance and sustainability are few such advantages.

This paper outline application of various construction materials in modern architecturally driven structures and structural challenges associated in design and construction. Design and detailing of timber and its connections in an eco-friendly single storied villa construction discussed firstly. Application of structural steel as construction material in an iconic pavilion is discussed. Important aspects with respect to analysis, design and detailing of complicated steel structures is emphasized. Finally, benefits on adopting steel-concrete composites in new construction and retrofitting of existing structures were discussed. Throughout the paper emphasis were made to demonstrate important structural considerations and constructability.

### 2. Timber as construction material in eco-friendly villas

Timber is a very ancient construction material very less frequently used as structural member in the permanent structures currently. Figure 1 shows an eco-friendly tourism development

consist of timber villas. The structures proposed in this development are architecturally designed following a well-known mathematical form 'golden ratio'. To achieve the complex geometry developed from this concept steel is used in combination with timber for wall plates as shown in Figure 2. Figure 3 shows typical structural elements of a villa made out of timber.

Unique connection details were utilized to connect timber to timber, and timber to other materials such as steel and concrete. Metal strips in combination with bolts and self-tapping screws were used for the connections. Connection between reinforced concrete foundation and timber column, connection of timber rafters at wall plate and ridge are shown in Figure 4, 5 and 6 respectively.



Figure 3: Eco-friendly villas with timber as construction material.



Figure 3: Steel and timber used in combination to form the complex structure.

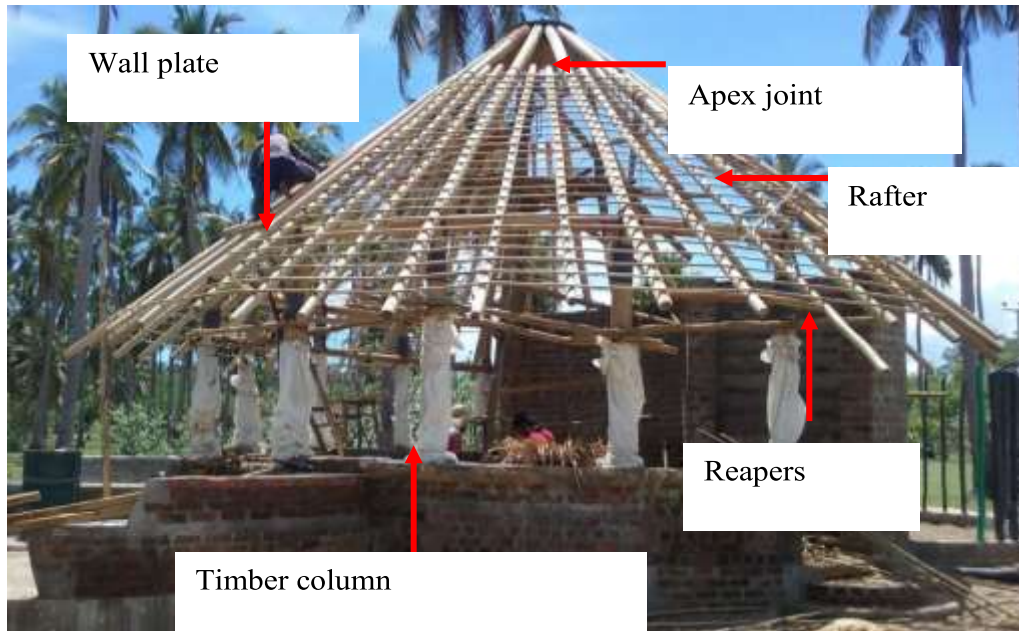

Figure 3: Typical structural elements of a timber villa

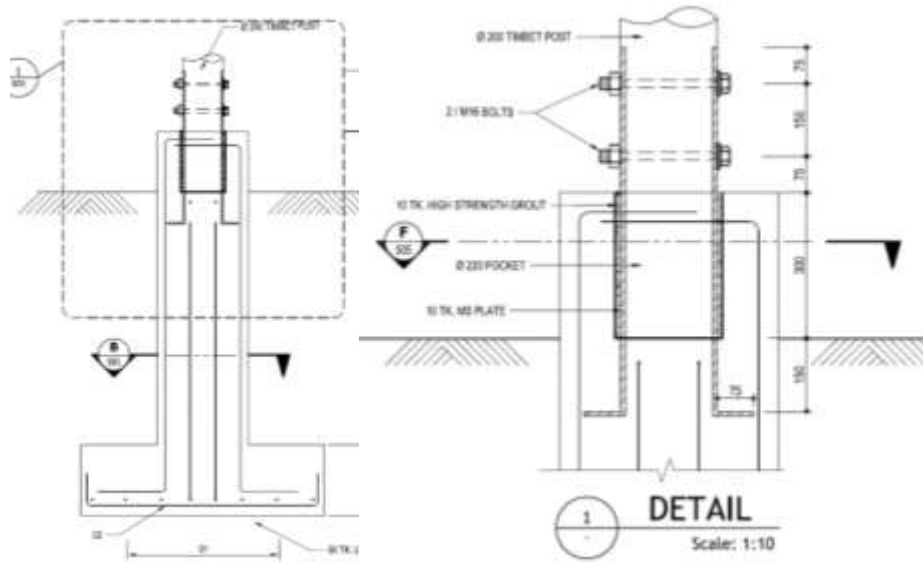

Figure 4(a): Connection of timber column at foundation.

Figure 4(b): Exaggerated detail of timber column fixing at foundation.

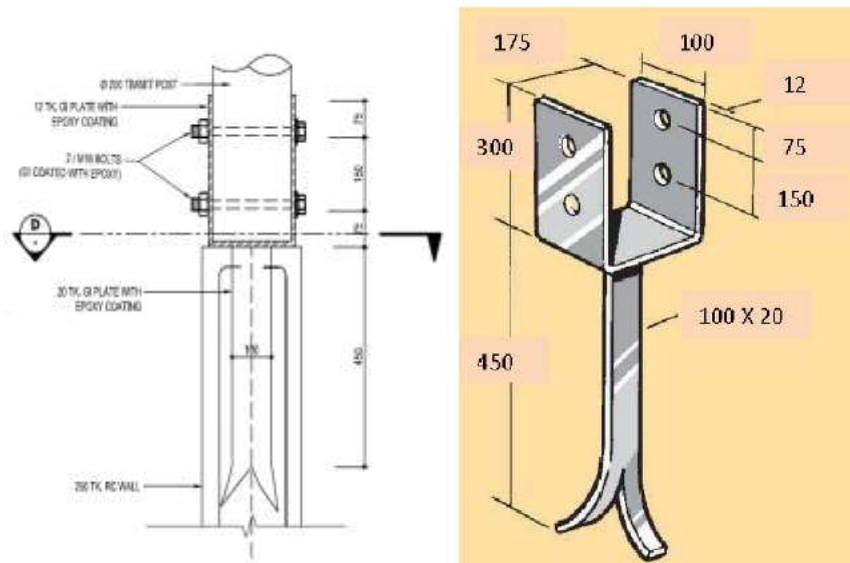

Figure 4(c): Connection of timber column at foundation without embedment.

Timber column with embedment in concrete as shown in Figure 4(b) was used where required stub column size can be accommodated in the

architectural design. Whenever stub column size is restricted, steel bracket configurations as shown in Figure 4(c) is adopted.

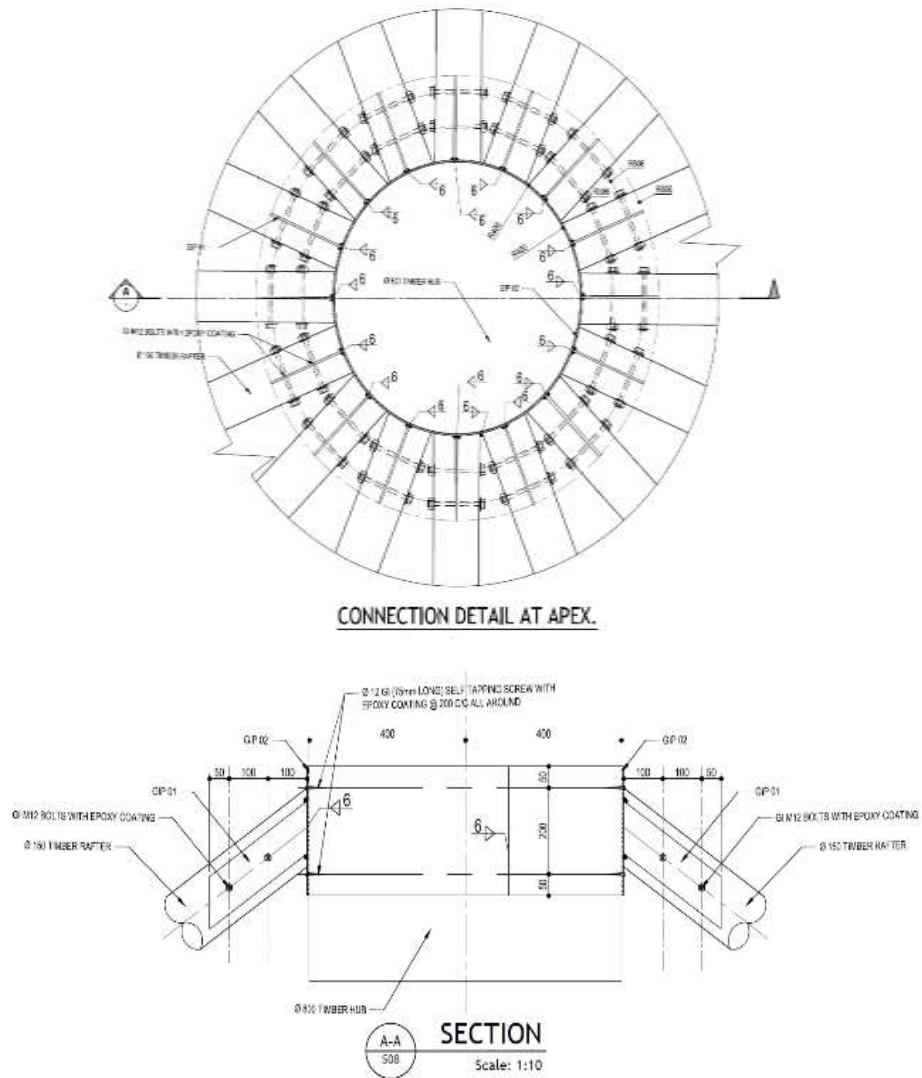

Figure 5: Connection of timber rafters at the ridge.



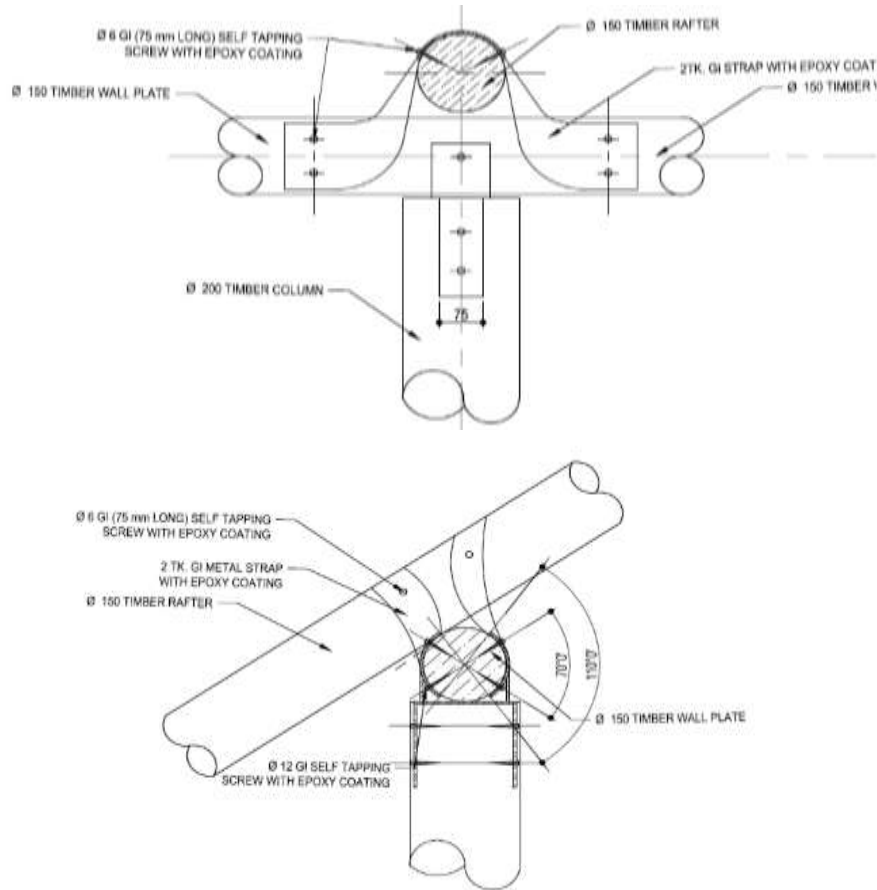

Figure 6: Connection of timber rafters to wall plate

Structural analysis of the complicated structures were performed using a Finite Element based software SAP 2000. FE model of a selected timber structure in the development is shown in Figure 7.

In order to demonstrate the constructability of this complex structure physical models were developed as shown in Figure 8. Completed form of the restaurant is shown in Figure 9.

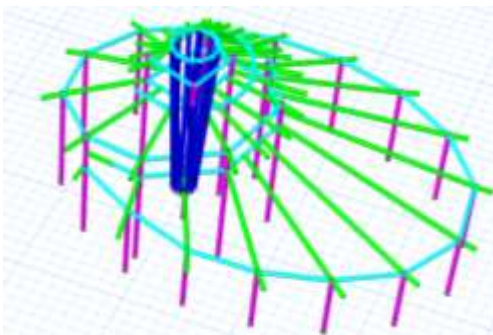

Figure 6: Structural analysis model of restaurant.



Figure 7: Physical model of a complex timber structure



Figure 8: Completed form of a timber structure.

### 3. Design of a pavilion with structural steel

Figure 10 shows an iconic pavilion designed for Colombo port city sales gallery. Architectural design is developed from an astrological octagon with leaning wall panels. Structural members located at the perimeter façade required to follow the path of the leaning wall panels. Universal steel beams were used for column sections as shown in Figure 11. The lightweight roof spanning 24 mx24 m in a two-way grillage system. Cantilever steel beams from leaning out wall were propped from the leaning in walls as shown in Figure 12. The props with circular hollow steel sections were architecturally positioned to the centre of the ceiling panels.



Figure 9: Colombo port city pavilion with octagon geometry.  
 (View on construction completion)



Figure 11: Structural elements of the pavilion.



Figure 11: Leaning wall panels of the pavilion structure.

Structural analysis of proposed pavilion was performed using SAP 2000 software. Based on the internal forces obtained from the analysis structural element capacities are verified. Figure 13 shows the Finite element model. In order to ensure the constructability of proposed complicated structural form a 3-dimensional BIM model (as shown in Figure 14) was developed using Revit software. The positioning of structural elements considering the placement possibility with orientation were critically checked using this model. Further, this model was used to effectively communicate the orientation of each structural elements and connection configurations to the contractor. Few of such connection configurations are presented in Figure 15 to provide an insight. The information provided from BIM modelling helped to minimize the clashes and transfer accurate information to the contractor. Accuracy could be maintained in fabrication and erection of the complicated structure.

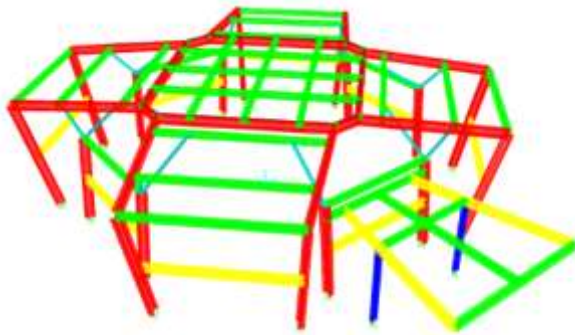

Figure 13: Finite Element model of pavilion.



Figure 13: 3-D BIM Model of pavilion.

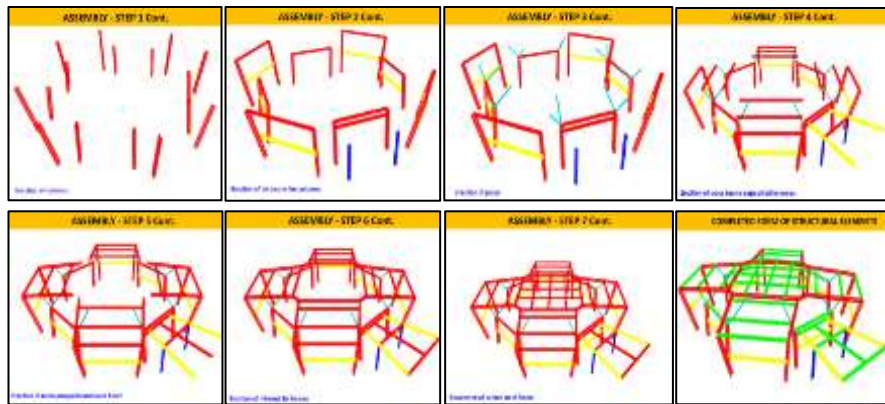

Figure 13: Construction stages of the pavilion structure recommended by the designer

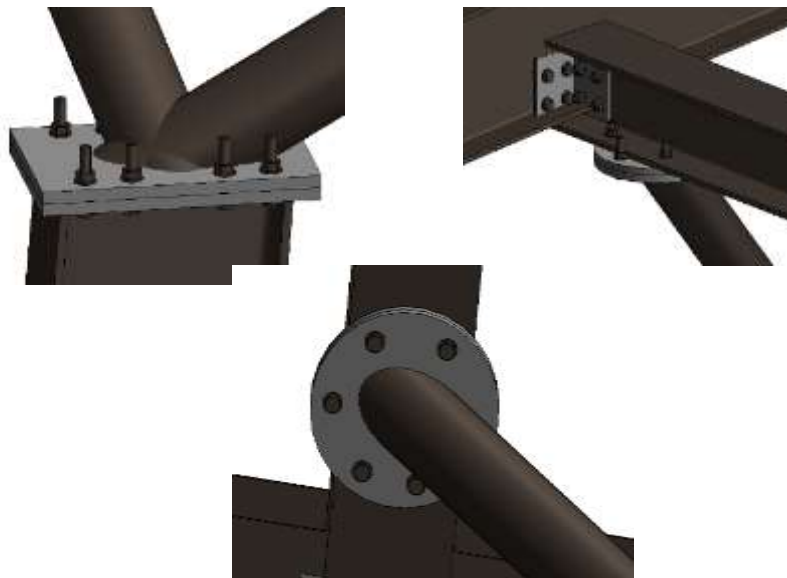

Figure 15: Presentation of few connection configurations of the pavilion extracted from Revit model.



It is important to ensure the stability of the structure during each construction stages. Considering the cantilevered nature of the structure a construction sequence analysis was carried out to ensure the stability and safety of structural elements. Based on the analysis, construction sequences as shown in Figure 16 were recommended by the designers to the contractor. Figure 17 shows one of the construction stage adopted during the construction. Based on the stability requirement base of the columns are designed and detailed as fixed joints (as shown in Figure 18).

arrangement was used to clad the structure as shown in Figure 20.



Figure 15: Construction of pavilion as per the construction sequence



Figure 15: Fixed joint adopted for steel column at foundation

A strip foundation system connected by ground floor with suspended slab was utilised to resist and transfer the internal forces expected from the fixed joint. Figure 19 show the strip foundation arrangement of the pavilion. A unitized curtain wall system well-coordinated with the structural



Figure 17: Strip foundation used to support the foundation.



Figure 17: Unitized curtain wall system adopted to clad the structure

#### 4. Steel-Concrete composite construction

##### 4.1 CFST for column with higher slenderness

Two low rise buildings with freestanding columns over three stories supporting the roof slab are shown in Figure 21. These circular columns positioned according to the Architectural requirements are free standing without any lateral restrains over 12 m and outer diameter of the columns to be limited to 300 mm. Even though the suggested slenderness limit of  $L_0/b < 60$  in the BS 8110-1:1997 and  $L_e/r < 180$  in BS 5950-1:2000 are not exceeded, both reinforced concrete and steel columns become as unrealistic solution due to the following facts;

- Higher deflection induced moment (BS 8110-1:1997) due to excessive slenderness of the reinforced concrete column requires enormous longitudinal reinforcement well beyond the allowable limit of BS 8110-1:1997 and found to be impracticable.
- Very low design compressive strength (BS 5950-1:2000) due to increased slenderness ratio requires significantly higher wall



thickness for steel circular column section. The standard market available hot rolled steel sections doesn't make the bare steel column solution viable and built up sections become uneconomical.

In order to overcome these limitations, steel and reinforced concrete were used in composite form as Concrete Filled Steel Tubular (CFST) columns. The design is carried out as per the requirements set out by BS EN 1994-1-1:2004. CFST is found to be very effective for this application as the wall thickness of the steel tube is reduced due to the higher effective stiffness, the composite section increase the design strength and concrete infill improve the resistance to local and global buckling of steel. However, in this case the concrete strength enhancement due to confinement affect is neglected as the slenderness is high.

Further, as per the simplified design provision given in BS EN 1994-1-2:2005 six percent of the longitudinal bars ( $A_s/A_c + A_s = 6.0\%$ ) are to be provided to obtain the two hour of fire resistance. Considering the constructability approximately 1% of longitudinal reinforcement is provided whereas the fire resistance is obtained through the application of intumescent protection coating. Self-compaction concrete mix with higher followability and small aggregate size is adopted to construct the infill.

The connection of the CFST column at the base and the roof slab is shown in Figure 22 and 23 respectively. Base plate with the hole equivalent to the column internal diameter is used for the base connection facilitating the erection of the column with continuity of longitudinal bars to the foundation. The low level of axial load present in the columns make this base plate configuration satisfied to meet the allowable bearing strength on concrete stub. Further, the unified column head developed in conjunction with architectural design is utilized to satisfy the punching shear design requirement of flat slab



Figure 18: Base plate for CFST column.

#### 4.2 CFST in inte

#### 4.3 rmediate rise steel building

Columns in steel framed buildings are subjected to higher level of axial loads due to the long spans. Using the composite columns inform of SRC or CFST is economically viable compare to bare steel columns due to increased strength and buckling resistance capacity. Figure 24 shows a CFST column adopted for a fifteen storied building. Here, CFST is found to be more feasible over bare steel and SRC due to following reasons,

- Reduction in steel consumption allows for cost saving
- Reduction in column size
- High stiffness minimize problems inevitable due to elastic axial shortening
- Connection with beams is convenience
- Formwork not required
- Construction speed is high



Figure 19: CFST column head detail at flat slab.



Figure 21(a): Application of CFST slender columns

Connection of CFST column at foundation level is shown in Figure 25. Here, providing holes for entire internal dimension of box section similar to the previous case is found to be impossible due to the higher bearing stresses exerted on foundation by the steel. Consequently, a base plate with holes only to accommodate the continuity of fire reinforcement is adopted. This require the high level of accuracy with minimum tolerance in positioning of rebar embedded in the foundation to facilitate the column erection.



Figure 20: Base plate for CFST column.



A typical connection of CFST with steel beams at floor level is shown in Figure 26. The proposed connection detail facilitate the convenience erection of the steel frame and found to be more viable to minimize the defects during the transportation from the fabrication workshop to the site. Addressing the constructability aspects in the design and the importance of detailing of connection is the CFST at various locations are well established from this case study. In both of these case studies presented above (in section 4.1 and 4.2) the full interaction between steel and concrete in the interface is considered as the shear stresses induced in the induction zone defined in EN 1994-1-1:2004 is found to be with in the allowable limits of interface shear due to friction.



Figure 21: CFST column connection at floor.

### 4.3 Steel Jacketing for Strengthening of existing reinforced concrete column

Significant requirements arise for strengthening of existing RC columns in the building industry due to the factors such as, design alteration with additional floors, construction defects, change in floor functions etc. Reinforced concrete jacketing, wrapping of fibre reinforced polymers (FRP) and steel jacketing are commonly known techniques available for such strengthening work. Figure 27 shows a tall building project site which had a requirement to increase 10 number of floors after the construction columns above the foundation level. As a results, the capacity of the certain columns had to be increased by more than 30% of the currently available capacity. Based on

the desktop study conducted steel jacketing technique is found to be the most feasible solution over the others to meet increased level of axial force demand with the minimum disturbance to the floor functional requirements.



Figure 22: Existing columns to be strengthened

Composite column design provisions of BS EN 1994-1-1:2004, ACI 318M-99 design criteria and the research findings of Bsisu (2002) and Richart (2004) are utilized with the judgement of Authors in the design of proposed strengthening. The literature review conducted by the Authors during this exercise express that the lack of publication on experimental investigation, design guideline and construction methodology of steel jacketing strengthening is exist. However, only an emphasize of the case study is made here for the conciseness of this publication. In contrast to the full interaction between steel and concrete considered in the composite design approach discussed in previous two cases, here mechanical shear connectors (as indicated in Figure 28) are provided as the interface shear demand is much higher than the allowable interface shear.

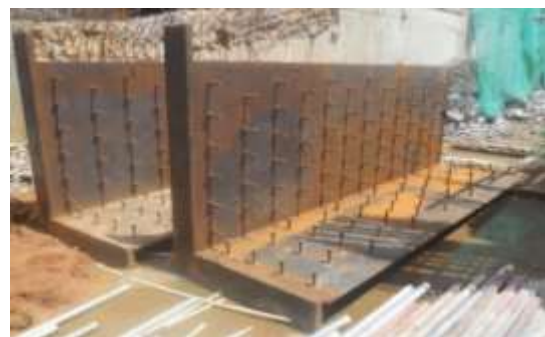

Figure 23: Shear connectors for steel jacketing.



## 5. Conclusion

This describes application of various construction material such as timber, steel and composites in modern construction industry. Importance of understanding structural behaviour, developing structural solution in line with the architectural design intent were discussed. Emphasizes were made in finding challenging structural solution from the structural analysis, design, detailing and constructability. Several examples as case studies were used from author's experience in Sri Lanka. The approaches and methodologies adopted in providing structural solutions for modern architecturally driven projects outlined in this paper summarise information collected from various literatures by authors during these excise.

Based on the design case studies discussed in this papers following conclusions/ observations can be made;

- Timber is a sustainable material for single storied eco-friendly villa construction. Challenges in design of various joints between timber elements and with foundation were presented.
- Application of structural steel in a sophisticated pavilion structure were discussed. Idealization, design and detailing of steel work connection and its influence on con-trolling structural behaviour were high-lighted.
- Advantages of Building Information Modelling (BIM) for structures with complicated geometries were highlighted.
- Application of steel-concrete composites in columns of multi-storey buildings were discussed. Design approaches and detailing methods of connections were emphasised
- Limitation on existing design provision for design of steel jacketing method for column strengthening was discussed.
- Detailed case studies for each of above cases were presented to provide a clear

insight on the structural challenges associated with modern structures and advancement in construction materials.

## References

- Bridge, R.Q., Pham, L. and Rotter, J.M. (1986), "Composite Steel and Concrete Columns - Design and Reliability", Proceedings, 10<sup>th</sup> Australasian Conference on the Mechanics of Structures and Materials, Adelaide, Aug, 1986, pp. 33-38.
- Bsису,K.I 2002, Retrofitting of square rein-forced concrete columns with steel jackets, Ph.D. Thesis, University of Jordan.
- Richart, F.E., Brandtzaeg,A., and Brown. R.L. 1928. A study of the failure of concrete under combined compressive stresses. Engineering Experimental station, Bulletin No.185, University of Illinois, Illinois, USA.
- EN 1994-1-1:2004 "Design of Composite Steel and Concrete Structures",
- EN 1993-1-1:2005 "Design of Steel Structures"
- EN 1992-1-1:2004 "Design of Concrete Structures"
- BS 5950-1:2000, "Structural Use of Steelwork in Buildings"
- EN 1994-1-2:2005 "Fire Design of Composite Steel and Concrete Structures",
- Susantha, K.A.S., Kiriparan, B. and Nirusan, A. (2013). "Dynamic characteristics of stiffened steel rigid frames." 4<sup>th</sup> International Conference on Structural Engineering and Construction Management 2013, ICSECM, Kandy Sri Lanka, December 2013.
- Bridge, R.Q., O'Shea, M.D. and Zhang, J.Q. (1997), "Load-Moment Interaction Curves for Concrete Filled Tubes", Proceedings, 15<sup>th</sup> Australasian Conference on the Mechanics of Structures and Materials, Melbourne, 8-10 Dec., pp. 141-146.