

CONSTRUCTION & DESIGN TECHNIQUES USING IN THE CURTAIN WALL SYSTEM

Eng. K. Jeyamohan,

*B. Sc. Eng (Hons) (Peradeniya), M. Sc. Eng (Struct-Reading) (Peradeniya), AMIE (SL), AMSSE (SL),
Lecturer (Construction Technology), Faculty of Technology, University of Jaffna.*

Abstract: - This paper describes the construction and design techniques of the curtain wall system which are currently using in the curtain wall Industry. Nowadays, Unitized & Semi Unitized are major types of the curtain wall system using in the industry. Unitized curtain wall system is commonly used for high rise building and also semi unitized curtain wall system is used for low rise building due to construction & installation issues. Curtain wall panel is mainly made by using aluminium extrusion with glass panel.

Structural adequacy, provision of movement, control of thermal & weather tightness are the major design considerations in the curtain wall design. Some of the techniques are using in the industry to control the above design considerations within the allowable limits. Stack joint design is an important for the provision of the vertical & horizontal movement between the panels of the curtain wall system. Also moment, shear, axial, deflection and lateral torsional buckling checks are major capacity checks involving in the curtain wall design. Using anti-buckling clip technology in the mullion profile is an effective method to avoid the lateral torsional buckling failure in the curtain wall system.

Keywords: - Unitized Curtain wall, Extrusion, Stack Joint & Mullion.

1. Introduction

Curtain wall systems are widely used in the construction industry as a building envelope. Generally four sides of the glass panel fix to the alum extrusion using structural sealant & extruded profiles. In the curtain wall panel, vertical member is called as mullion and horizontal member is called as transom as highlighted below in Fig-1.

Curtain wall system is mainly divided into two categories based on installation method as mentioned below.

- 1) Unitized Curtain wall: - fabricate the whole panel (Alum framing with glass panel) in the factory and install the whole panel at specific location of the building.
- 2) Semi-Unitized Curtain wall: - fabricate the alum framing in the factory and install the glass panel at site after installation of frame at specific location of the building.

Unitized curtain wall system is the best technology which is using in the high rise building.

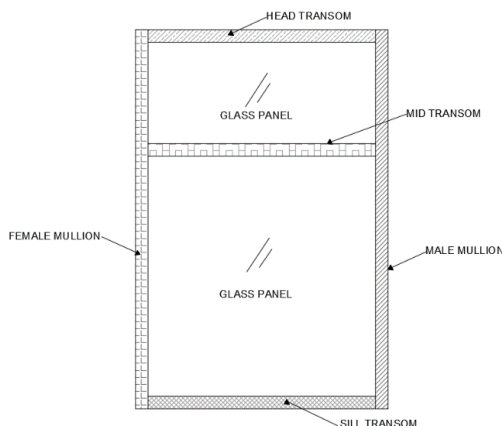

Figure 1:- Unitized curtain wall arrangement

2. Design considerations of Curtain wall

Curtain wall system act as a building envelope. So that, design of this curtain wall panel should be carefully considered the following load cases.

- Self-weight of the panel
- Wind Load
- Barrier Load / Imposed Load

Nowadays, in order to obtain the accurate wind pressure on the envelope, wind tunnel test is major requirement for the most of the slender and uneven shape of high-rise building.

Addition to wind load, barrier impact load also should be considered depends on the building type & usage. Using above loads and load combinations, structural adequacy of the curtain wall panel should be checked with adequacy of moment capacity, shear capacity, axial capacity, Lateral torsional buckling capacity and deflection check based on serviceable & ultimate limit states. Based on the unitized curtain wall installation method, analysis of mullion is usually as a simply supported beam. One end is considered as a pin joint and other end is roller support.



Figure 2a: Sample of wind tunnel test Model arrangement

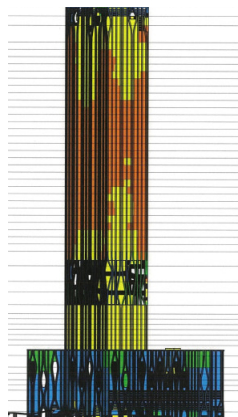

Figure 2b: Wind pressure variation over building envelope

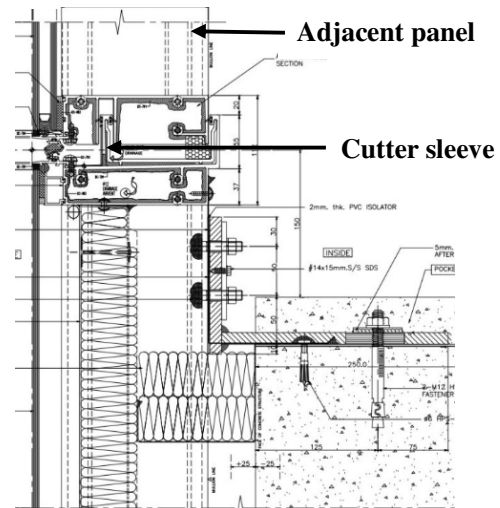

Figure 3: Curtain wall fixing with RC Slab

As shown in Fig 3, one end of the panel is fixed with main structures and other end is interlocked with adjacent panel using cutter sleeve. Cutter sleeve should be designed to cater the part of the lateral load from adjacent panel.

So, high grade strength material should be used as a cutter sleeve with adequate length and thickness to cater this high concentrate lateral forces from adjacent panel. In the curtain wall industry, normally using 6061-T6 aluminium grade (Yield strength = 240MPa) for the cutter sleeve.

3. Stack Joint in the Curtain wall

Provision of movement joint is an importance criteria in the curtain wall system due to following reasons. This joint also known as a "Stack Joint".

- Deflection of the slab/beam
- Column shortening
- Thermal expansion of the members
- Installation tolerances
- Fabrication tolerances

Improper stack joint design leads the cracks and damage on the glass panel as well as on the curtain wall frame. Fig 4, clearly indicates the stack joint provision on the curtain wall system.

Min required stack joint space >

(Deflection of structures due to loading + Column Shortening + Thermal expansion + Installation & fabrication tolerances)

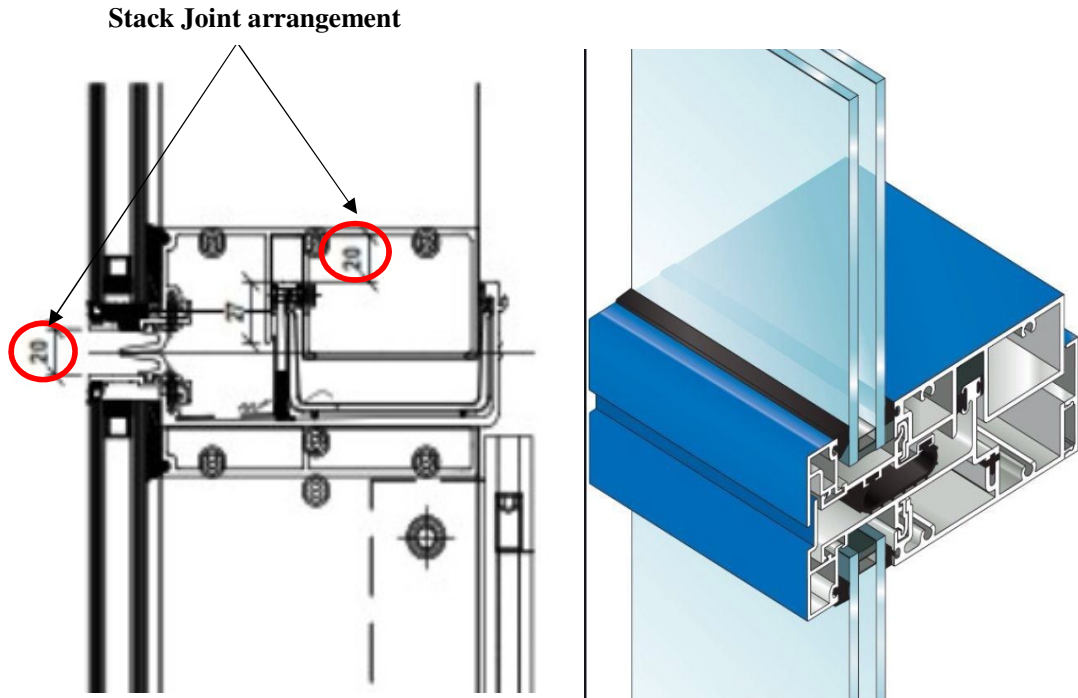

Figure 4: Curtain wall stack joint arrangement

Also, stack joint can be divided into two categories as shown below.

- 1) Vertical stack joint: - provision of movement joint between the head and sill transom.
- 2) Horizontal stack joint: - provision of movement joint between the male & female mullion.

So, vertical and horizontal stack joint should be carefully considered on the time of design and installation of the curtain wall system.

4. Lateral Torsional Buckling Capacity of the Curtain wall system.

Generally, aluminium extrusion is used as a main frame members of the curtain wall system. Also 6063- T5/T6 alum grade series using in the industry to extrude the alum profiles. These grades aluminium yield strength values are in between 110-160MPa. Lateral torsional buckling capacity check are correlated with clear distance between the lateral restraint, second moment of inertia of major & minor axis, torsional and warping parameters of the extrusion profiles and yield strength of the profile.

In order to comply the Architect and other limitations, mullion profile is to be designed with limited depth and width. So, second moment inertia of minor axis is normally smaller than major axis of the extruded profile. Based on the shape and function of the profile, complying the lateral torsional buckling capacity of the female mullion is getting issue on the time design stage. Increasing the profile thickness is not advisable way as related to the cost of the project.

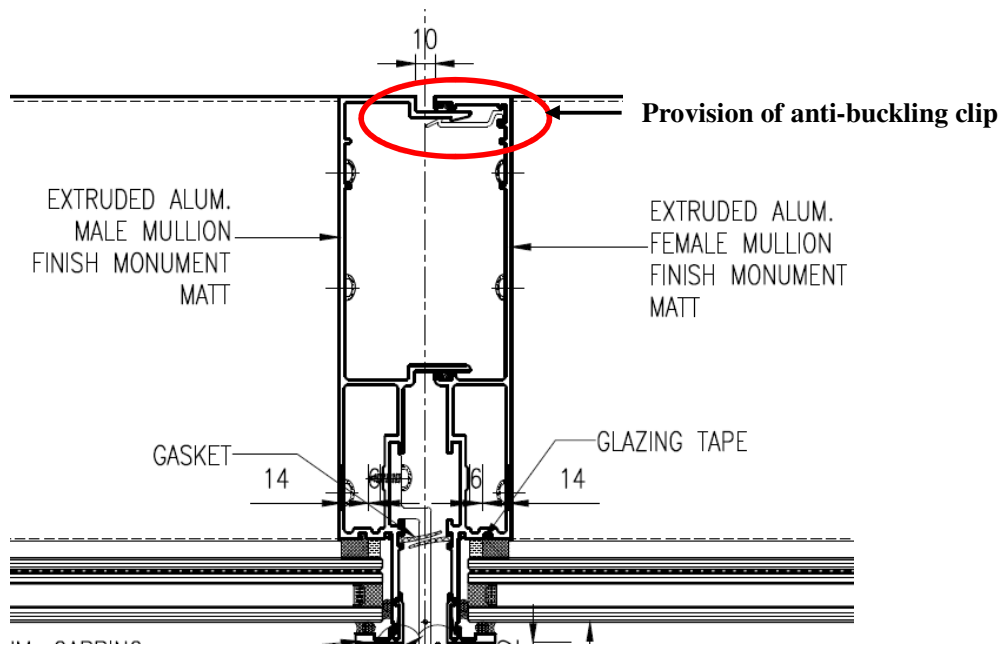

Figure 5: Anti buckling arrangement in the curtain wall system

So, using the “Anti-buckling clip” is one of the advisable technology which is using in the façade industry as shown in the fig 5.

Due to provision of the anti-buckling clip, male and female mullion are restrained along minor axis. So, lateral movement of the curtain wall system is more stiffened due to combination of both profile. Also, consideration of clear distance between the lateral restraints become smaller, so that, there is a much increment in the lateral torsional buckling capacity of the mullion profile. So introducing of the anti-buckling clip, helps to save the weight of the profile.

5. Conclusions

Design of curtain wall system should be structurally adequacy against the wind and lateral loads. Provision of stack joint and proper thermal and water tightness are the major considerations for the long term stability of the curtain wall system.

Improper stack joint design leads to sudden cracks on the glass panel. So that as discussed above, all the parameters should be carefully considered in the design of stack joint system. Also, provision of anti-buckling clip helps to reduce the weight of the profile or saving the material by increasing the lateral torsional buckling of the mullion profile.

References

- 1) EN 1999-1-1 (2007): Design of Aluminium structures (Eurocode 9).
- 2) Wong wan sie., Winxie., “Analysis and design of curtain wall systems for high rise buildings”, ENG4111 and 4112 Research project.
- 3) BS 6399-1:1996 – Loading for buildings, code of practice for the dead and imposed loads.
- 4) Zhenwen Gong., Bin Zeng., Weichi Han., Suduo xue., “ Discussion of structure design and optimization of curtain wall” , open journal of civil engineering, 2017, 7, 303-310.
- 5) AS 1288 (2006) ‘Glass in Buildings – Selection and Installation’, Australian Standard.